

型號	MODEL	BS65
棒材直徑	BAR DIAMETER	5 - 65 mm
棒材容量	BAR CAPACITY	65 mm / 10 pcs 最長 1.2 / 1.5 / 1.8 M 視車床主軸而定
棒材長度	BAR LENGTH	MAX 1.2 / 1.5 / 1.8 M DEPEND ON MACHINE SPINDLE LENGTH
機械總重	MACHINE WEIGHT	320 / 360 / 410 KG
空壓供應	AIR PRESSURE	6 kgf / cm ² 70psi
電源供應	POWER SUPPLY	220v
消耗功率	POWER CONSUMPTION	575W

若需要其他資料請上網查詢 Check our website for more details Web Site: www.barload.com.tw

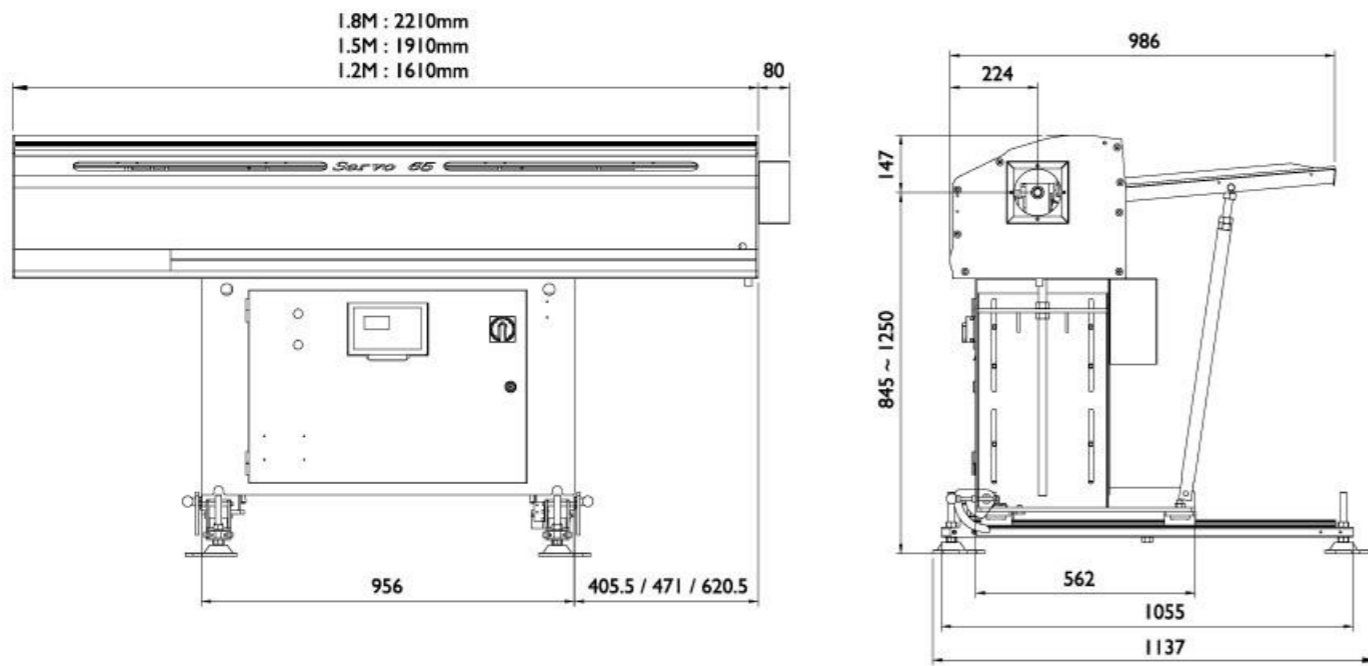

BARLOAD[®]
Automatic Bar Feeder

富豪機電股份有限公司
BARLOAD MACHINE CO., LTD.

No. 138, Wei-Hsin Road, Shi-Pai Li, Chang-Hua City, Taiwan 50080

50080彰化市石牌里維新路138號

TEL: +886-4-7384895 FAX: +886-4-7320282

E-mail: info@barload.com.tw

www.barload.com.tw

經銷商 Agent

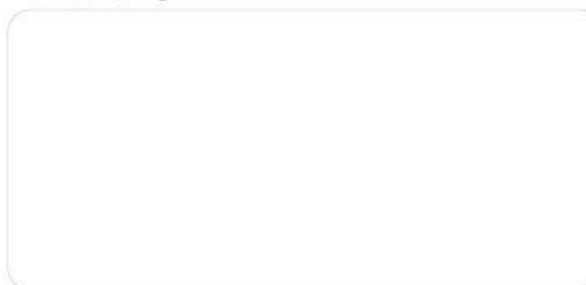

本公司保留設計變更的權利 All Rights Reserved.

15737501404CE

BARLOAD[®]
Automatic Bar Feeder

www.barload.com.tw

Servo 65

創新研發 · 台灣領航
品質追求 · 世界第一

Quality Innovation
Reliability Experience



BS 65
系列 Series
5 - 65 mm

SHORT BAR FEEDER

短棒材送料機



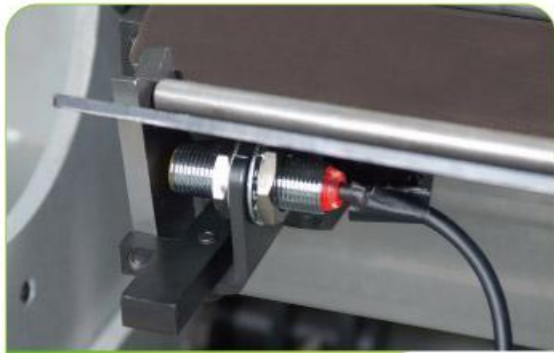

切端結構
Top-cut Configuration

- » 切端機構穩定，小棒材亦可精密偵測。
- » New design top-cut system, precision measuring with small diameter.



電控系統
Electrical system

- » 內部PLC控制，易與任何CNC車床搭配。
- » Fully-functional PLC control combined with comprehensive data bank software. Perfectly interfaced with the CNC lathe.



伺服馬達
Servo Motor

- » 伺服馬達送料快、準、順暢。
- » Servo feeding fast and accurate, no risk of impact by the bar on the lathe clamping cylinder.



置料調整
Adjustable Bar-magazine Rack

- » 更換材料尺寸，下料機構易於調整，簡單、快速。
- » An easy adjustment of change-over on barstock sizes.



中心調整
Adjustable Loading Center

- » 材料尺寸調整送料機構：易於調整、容易、快速。
- » Quick and easy adjust loading V channel, simple and save time.



手控器
Movable Remote Controller

- » 手控盒，易於操作，符合人體工學。
- » Hand held remote control greatly increases operator control at machine.



移動式腳座
Retraction Device (Movable Rail)

- » 移動式腳盤，方便主軸維修，更換皮帶，主軸襯套。
(選購 X 向及 X+Z 向 兩種規格)
- » Movable rail, convenient for machine service, change belt or spindle liner.
(Option for X way or X+Z way)

- 可提昇CNC車床加工中，工件速度與精密度，無震動問題。
- 黑皮材料，可適用。
- BS65送料機佔地空間小。
- 人機界面控制，操作與設定異常故障排除容易。
- 移動式手控盒，方便操作，符合人體工學。
- 伺服馬達與線性滑軌結合，送料時，快、準、順暢。
- 更換材料、調整機構，簡易方便。
- 移動式腳盤，方便主軸維修、更換皮帶、主軸襯套。(選購)
- 外部LED顯示位置棒材長度及異常訊息明顯易見。
- 新下料方式，減少噪音，調整方便。

- Productivity increase and reduce manufacturing cost
- No vibrations, allows precision machining at high speed.
- Fast and smooth bar loading cycle
- Smoothly pushing motion combine with liner guide.
- Loading V channel easy to adjust.
- Convenient remote controller.
- External LED display, more easily to monitoring feeding situation.
- Movable rail make machine service easier.
- Servo feeding combine with liner guide, permits accurate positioning bar without turret stop.
- Friendly display easy to setting and trouble shooting.

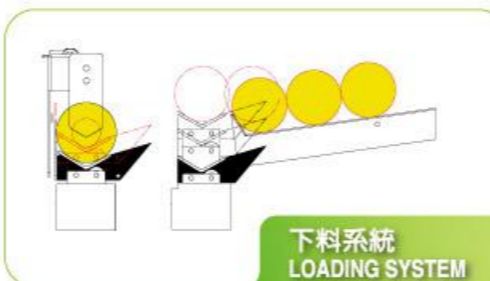

下料系統
LOADING SYSTEM

BS 65
系列 Series

SHORT BAR FEEDER

短棒材送料機